



An Optimised Traffic Control Scheme with Preference to Emergency Vehicles Leveraging RFID

Kenneth Akpado¹, Samuel Usoro^{2*} and Nneka Ezeani²

¹*Department of Computer and Electronic Engineering, Nnamdi Azikiwe University, Awka, Nigeria.*

²*Department of AI and Robotics, Electronics Development Institute, Awka, Nigeria.*

Authors' contributions

This work was carried out in collaboration among all authors. All authors read and approved the final manuscript.

Article Information

DOI: 10.9734/JERR/2021/v20i1017391

Editor(s):

(1) Dr. Guang Yih Sheu, Chang-Jung Christian University, Taiwan.

(2) Dr. Neha Munjal, Lovely Professional University, India.

Reviewers:

(1) Trung Nguyen, University of Toronto, Canada.

(2) G. Saravanan, Anna University, India.

Complete Peer review History: <https://www.sdiarticle4.com/review-history/69365>

Original Research Article

Received 06 May 2021

Accepted 10 July 2021

Published 22 July 2021

ABSTRACT

Emergency Vehicles (EV) such as ambulances, fire fighting vehicles, Road safety vehicles and other emergency vehicles encounter delays on their missions at traffic light control points due to traffic jams. The direct consequence of these delays results in unwarranted loss of lives and properties. This research work proposes and implements an improved traffic control system with preference to emergency vehicles leveraging RFID technology and a novel Dynamic Traffic Sequence Algorithm (DTSA). Atmega 328 was used to actualize the novel DTSA, control the RFID and the entire traffic control system. The distance of RFID signal transmitted by the emergency vehicle was determined by physically measuring the distance of clearer signal obtained at various distances from the test bed. MATLAB was used to plot the response time of the RFID, thereby helping in the choice of RFID used. It was observed at 100 meters distance between the RFID transmitter in the emergency vehicle (EV) and the traffic light system, a clearer signal was obtained. Therefore at 100 meters the emergency vehicle will be detected and the traffic system will reset its normal routine to give right of way to the particular lane that the emergency vehicle is detected. Comparing the old and the new system it was observed that in the new system the EV will be 12minutes faster than the EV in the old system. From the result obtained, the RFID best suited for this application is active RFID. The results obtained proved that the system will effectively mitigate and almost completely eradicate the delay encountered by emergency vehicles at traffic control points. The system will be deployed in any many cities in Nigeria that have traffic control systems installed.

*Corresponding author: Email: samuelusoro7@yahoo.com;

Keywords: RFID; EV; DTSA; traffic light control.

1. INTRODUCTION

The growing number of vehicles, traffic congestion and transportation delay on urban roads are increasing worldwide. Emergency vehicles such as ambulances, fire fighting vehicles, road safety rescue vehicles, National Emergency Management Agency (NEMA) vehicles and crime fighting vehicles are required to reach their destinations as quickly as possible. Unnecessary delays experienced by this emergency vehicles may result in damages of properties and loss of lives. Reasons for the damage caused are usually attributed to delay in traffic hold up at road interceptions with traffic lights.

Whenever an emergency vehicle is travelling under conditions of urgency, the problem of passing through busy street intersection poses dangerous problem to both the emergency vehicle occupants and other road users within the vicinity of intersection. The problem in Nigeria especially, has become severe in recent years when many drivers travel in air-conditioned cars with their windows rolled up and often with loud sound of music to the extent that they are unable to hear the siren of an approaching emergency vehicle. Many serious accidents in Nigeria cities and towns that occur nearly every week is as a result of collision between emergency vehicle and other vehicles on the traffic particularly as they approach a traffic light system.

One of the most outstanding delays that affect emergency vehicles is the time that is consumed on traffic holdups between the starting point and the destination point of these vehicles; in intersections with traffic lights, especially when these intersections are congested [1].

This research work tries to eliminate these challenges by giving preferences to these emergency vehicles with the use of Radio Frequency Identification (RFID) technology. This system will help alleviate the problem of delay encountered by emergency vehicle by automatically pre-empting the traffic lights and giving the emergency vehicle right-of-way when the system sensed the vehicle at a given distance. The proposed Radio Frequency Identification (RFID) traffic control avoids problems that emergency vehicles usually encounter with normal traffic control systems. The RFID traffic light control system which

includes two-way communications between a moving emergency vehicle approaching a busy intersection with one or more traffic apparatus, are arranged so that the traffic light control apparatus has stored therein pre-set patterns of response that temporarily alter its timing and pre-empt the usual operation of the traffic light by providing right-of-way to emergency vehicle in preference to other vehicles [2]. The proposed on-board architecture (RFID) is portable and easily adaptable to any brand of car with minimal modifications. The proposed system will have optimum solution for the delay time experienced on the emergency vehicles along roads. Traffic lights must be equipped to receive an activation signal to be controlled by any system intended for use in that area. A traffic signal not equipped to receive a traffic pre-emption signal will not recognize activation, and will continue to operate in its normal cycle. These problems can be solved if the traffic control system uses two-way communication links between emergency vehicles and traffic control apparatus at intersections. [3].

1.1 Problem Statement

Owing to the fact that delays experienced by emergency vehicles such as ambulances, fire fighting trucks, road safety rescue vehicles, National Emergency Management Agency (NEMA) vehicles and crime fighting vehicles from law enforcement agencies get stuck in unavoidable traffic which has in many cases culminated in the needless loss of lives and destruction of property there is a need to develop a system that effectively and rapidly alters the sequence of traffic light control at road interceptions whenever Emergency vehicles in emergency situations get trapped in long queues.

1.2 Literature Review

Most of the works reviewed in this section are based on emergency vehicle signal preemption, preemptive control and vehicle priority. They all centered strictly on granting right of way to any emergency vehicles without considering a situation where two or more emergency vehicles on different missions approach a road interception from different routes at the same time. Also, all the reviewed works have no voice prompt to alert other road users of the approach of emergency vehicles.

The U.S. Department of Transportation Federal Highway Administration in 2010 developed a device which was published in their Manual on Uniform Traffic Devices for Streets and Highways [3]. Here, the driver of an emergency vehicle has total control by temporary resetting the traffic apparatus to give himself right of way. The major issue with this control device was that is very complex, for example, if the driver forgets to reset the system after passing, the system will still give right of way to that particular route continuously.

In the work done by Vanny and George, [4]. Traffic signal light control system using RFID technology. They suggested that traffic signal preemption systems should be integrated in only emergency vehicles that ply a particular route within a particular metropolis. The typical cross arms and warning lights at nearby traffic intersections prevent excessive road traffic from approaching the crossing. The main problem with their work was that it will only limit an emergency vehicle to a particular route in a city.

Urbanik, et el, [5] developed a Traffic Signal State Transition Logic Using Enhanced Sensor Information. In their work, an emergency vehicle may send a pre-emption request that instantly alters the traffic signal timing and or phasing to provide a green indication. It had two major issues; first, the normal signal operations process would be disrupted without informing other road users and then secondly other emergency vehicles from other routes at the same interception are not considered.

Maki and Pamela, [6] in their work; Acoustic and Adverse Weather Traffic Signal Timing, were able to develop a fairly inexpensive system to integrate into existing traffic signals with the ability to use siren equipment already installed in emergency vehicles – thus dispensing with the need for special equipment. The major challenge with their research was is that sound waves can easily be reflected by buildings or other large vehicles present at or near an intersection, causing the "reflected" wave to trigger a pre-emption event in the wrong direction.

Rajesh and Shahi,[7] in their work proposed an Intelligent Traffic Density Monitoring Using GPS. The GPS data of vehicles in a particular route in the city are collected by satellite and then the dynamic traffic system will automatically give right of way to the emergency vehicle that approaches the route. The limitation with this research was that GPS data isn't thorough because not all drivers of emergency vehicles on

a road use GPS to navigate. Also, Satellite images are affected adversely by weather conditions and require computationally intensive pre-processing to measure traffic density.

2. METHODOLOGY

2.1 Overview of Proposed DTS Algorithm and Model Description

The algorithm proposed in this research work dynamically controls traffic lights by collecting real time input from the RFID tag installed in emergency vehicles. While keeping in mind the concrete objective of minimizing the average waiting time of other vehicles, we also include a scenario involving the worst case (deadlock) condition for emergency vehicles. This algorithm offers a solution to problems encountered by emergency vehicles by giving priority to which emergency vehicle is on a more critical mission.

In the proposed emergency traffic management model, the traffic sequence will be dynamically managed. This research project will be carried out using Dynamic Traffic Sequence Algorithm (DTSA). DTSA is an algorithm for the control of the traffic sequence that can change dynamically and easy to implement. The algorithm is used to facilitate the efficient traffic control at road interception. This also can be extended to multiple junctions' control. It is based on an automatic intelligent selection of traffic sequence in a multilane traffic flow. In this work, the Arduino code will mimic this algorithm.

Tables 1 and 2 shows an example of how the DTSA works. Assuming A, B, C and D are traffic column or lanes in which A from south can go forward, east or west, with timing slot that is dynamically determine according to the number of vehicles for each route. The same sequence is then shifted to B, C then D.

Table 1. State table for the traffic lights

Next state	0	1
R	R	G
Y	Y	R
G	G	Y

Table 2. State table for traffic lanes

Next state	0	1
A	A	B
B	B	C
C	C	D
D	D	A

DTSA for A to wait is given as:

$$A_{wait} = BG + CG + DG + AY + BY + CY + DY$$

$$A_{wait} = BG + CG + DG + 4(3s)$$

$$A_{wait} = BG + CG + DG + 12s$$

Where

$A_{wait} \neq B_{wait} \neq C_{wait} \neq D_{wait}$
 The Arduino IDE will mimic this algorithm using the given variables. Table 3 shows the waiting time for each lane using DTSA.

Table 3. Waiting time at each state

State	Waiting Time at each state
A	AY + BG + BY + CG + CY + DG + DY
B	BY + CG + CY + DG + DY + AG + AY
C	CY + DG + DY + AG + AY + BG + BY
D	DY + AG + AY + BG + BY + CG + CY

2.2 Design Requirement

2.2.1 Hardware/ electronics requirement

- ATmega 328 Microcontroller.
- Crystal Oscillator (12 Mhz)
- RFID (Receiver and Transceiver)
- Arduino 1.83 Software (IDE)
- Transistors.

2.3 Hardware Design

The entire system is made up of five blocks as shown in Fig. 1.

- The Traffic lights: This comprises of the lamb heads with three lights and the poles.
- Power supply: Ac source of 5volts.
- Controller: The controller is ATmega 328 microcontroller.
- Emergency vehicle/RFID transmitter and transceiver.
- Sound buzzer.

The entire system is made up of seven blocks that are network together. These include: the RFID tag, RFID Transceiver, RF receiver, Controller, Buzzer, Traffic lights and the power supply.

2.3.1 RFID tag / encoder (in the emergency vehicle)

This block has a RFID tag, a transmitter and a configurable encoder. The tag with the encoder

will be installed in an emergency vehicle. The encoder will be configured to give a unique ID to all emergency vehicles in the particular state or city that the system will be deployed. All the emergency vehicles in the city will be registered and a unique ID will be given. This is to prevent unauthorised motorist from buying RFID tag and installed in their car to enjoy the free flow of traffic at traffic interception. The RFID transmitter will be transmitting a radio frequency signals at 315Mhz. The signals will be detected and received at 50 meters from the intermediate transceiver.

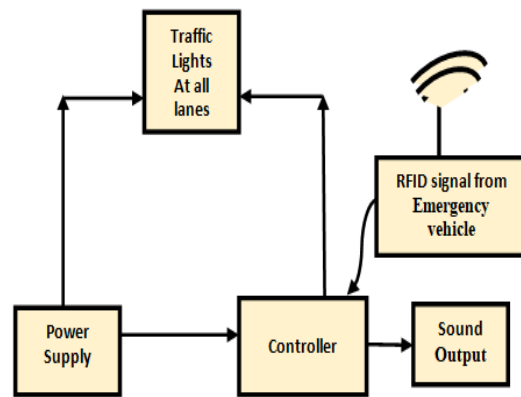

Fig. 1 Block diagram of the system

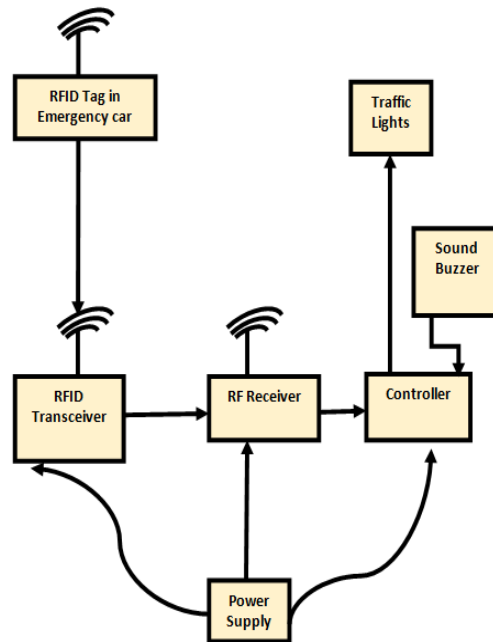

Fig. 2. Block diagram of the entire traffic unit with an emergency vehicle

2.3.2 RFID intermediate transceiver

This block has three basic sub sections which include a receiver, a decoder and a transmitter. The receiver detects an emergency vehicle 50meters away from it It receives the RF at frequency of 315Mhz. the decoder decodes an encoded unique Id of the emergency vehicle. The transmitter transmit the emergency car Id and the lane Id of the transceiver to the control section of the traffic lights. It transmits a RF of 433Mhz to the controller.

2.3.3 RF receiver

This is an active module of the controller. It receives both RF tag with unique ID of the emergency vehicle at 433Mhz and the lane Id that the emergency vehicle is detected. The both signals were transmitted by the intermediate transceiver at frequency of 433Mhz. It passes the information received to the main controller for appropriate action.

2.3.4 The controller

This is the brain of the entire system. It contols the normal traffic routine and the emergency response. The database of all the emergency vehicles Id resides here. It performs three basic emergency functions including: checking whether the emergency vehicle is genuine or registered, checking the lane that the emergency vehicle is coming and resetting the the traffic routine to give right of way to the emergency vehicle.

The traffic light controller is represented in the circuit of Fig. 3 The major components are Atmega 328p microcontroller (ATMEGA328P), a receiver (RF433B1), the buzzer (Bz1), capacitors, crystal oscillator, transistors and lamb heads.

The output pins of the microcontroller are used to switch the lights of the traffic controller. 1k is used to bias the base of BC337 transistor and cause Vcc(5V) to flow from emitter to collector at BC 337. The same principle is used to switch on the sound buzzer.

The circuit represented in Fig. 4 is the intermediate transceiver that will be installed at all the lanes leading to the traffic lights. The distance between it and the main controller will be 50 meters. The circuit has four basic components including: ATmega328p Microcontroller, Receiver (RF315B2), Transmitter

(RF433A1) and a Decoder (HT12D). Other components include, two Capacitors 22PF, Crystal oscillators, resistor R11 and LED2.

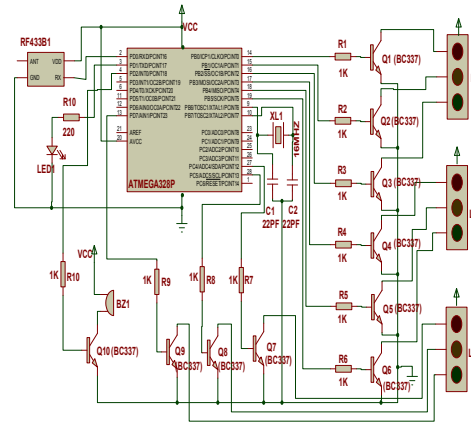

Fig. 3. Circuit diagram of the traffic control system

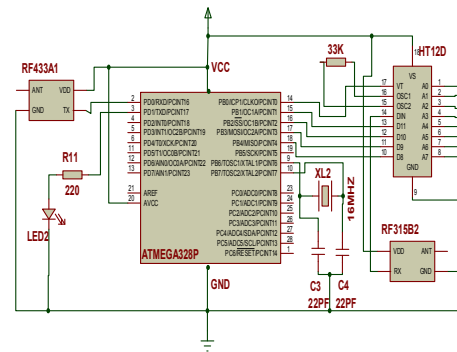

Fig. 4. Circuit diagram of intermediate transceiver

The RF315B2 receives RF signals at 315 MHz from the RFID tag in the emergency vehicle. The decoder decodes encoded ID of the emergency vehicle to ascertain whether the vehicle is authentic emergency vehicle. The RF433A1 transmits both RFID tag at 433 MHz and the lane Id of the particular lane that the emergency vehicle is being detected at the same 433 MHz to the main controller for appropriate actions to be taken. The ATmega328p Microcontroller at the centre of the circuit co-ordinates all these activities of reception and transmission that is taking place in the circuit. The microcontroller is driven by Arduino program.

The circuit diagram in Fig. 5 represents the RFID tag that will be installed in the emergency vehicle. It has two basic components including; an Encoder (HT12E) and a Transmitter (RF315A2). Other components include resistors R13 and R12. The encoder (HT12E) is configurable and will be used to assign a unique ID to all emergency vehicles in the particular city or state. The transmitter (RF315A2) transmit RF at 315 MHz to an intermediate transceiver that will detects the presence of an emergency vehicle at a distance of 50 away from the transmitter.

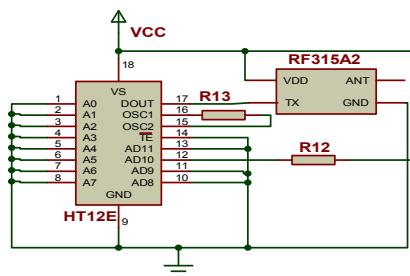

Fig. 5. Circuit diagram of RIFD tag

This research models an EV approaching a group of cars and their velocity distribution in traffic using a stochastic approach. The aim should be to effectively draw out a blueprint for the EV to navigate traffic during an emergency. Traffic systems shall also be modelled and applied to traffic problems of different kinds to find their solutions.

It is important to note that Traffic is the movement of motorized vehicles, unmotorized vehicles and pedestrians on roads. Traffic Flow is the pattern of the way people move through an area or road network, or a measure of the density of traffic. Traffic Jam means the number of vehicles blocking one another until they can scarcely move, that is a situation when all road traffic is stationary or very slow. Traffic Congestion is a condition on any network as use increases and is characterized by slower speeds, longer trip times, and increased queuing. It is noteworthy that in traffic systems, Red Phase means Stop, Green Phase means GO, and yellow Phase means Stand For or slow-down

Mathematical modelling is the process of creating a mathematical representation of some phenomenon in order to gain a better

understanding of that phenomenon. It is a process that attempts to match observation with symbolic statements. Mathematical Model is the representation of the essential aspects of an existing system (or a system to be constructed) which presents knowledge of that system in usable form.

“Stochastic” means being or having a random variable. A stochastic model is a tool for estimating probability distributions of potential outcomes by allowing for random variation in one or more of the input over time. The random variation is usually based on fluctuations observed in historical data for a selected period using standard time-series techniques.

The approach that we shall use here is as follows; we shall take Traffic as a MAS (Multi-Agent System) and Car as an Agent. We shall take as velocity V_i drawn from velocity distribution $P(v)$ and D_i as the delay factor. For convenience, we apply the following passing rules.

When a EV with velocity V_i approaches a group of other vehicles with velocity V_c , it is given a right of way with the probability W or it is denied the right of way with probability $1 - W$.

Passing probability W is given by

$$W(V_i \leq V_c) = \alpha(V_i \leq V_c \leq V_{av} D_i) \tag{4.1}$$

α is a step function and D_i is the same for all agents (cars) in the traffic jam

We will also make a modelling assumption of vehicular density to be ρ and each vehicle moves with its velocity drawn from a given (continuous) distribution $P_0(v)$ (we will measure the velocity, distance and time in units of initial average velocity $v_0 = \int_0^\infty v P_0(v) dv$, inverse density, and the average collision time $1/v_0$ respectively). When a EV is blocked in front by a traffic jam, it slows down and joins the traffic jam with probability $1 - W$. With probability W , it maintains its speed and given the right of way.

To incorporate this assumption into the model we adopt the following simple functional form for the passing probability

$$W(v \leq v') = \alpha(v \leq v' \leq vR) \tag{4.2}$$

Where $\alpha(X)$ is the step function, and vR is a parameter of a model that determines the balance between an EV (not passing and joining

traffic jam) and minimizing its travel time (passing and keeping its inherent velocity). If the no passing limit, $vR \ll v_{EV}$ would cluster behind other vehicles, which will bring the system to a congested phase at sufficiently high densities. In the opposite limit, $vR \gg v_{EV}$ passing occurs very.

Right of way is given as the EV maintains an inherent velocity.

We can assume that vR is the same for all the vehicles, the only source of the heterogeneity (disorder) is the initial distribution $P_0(v)$.

Let $P_m(v, t)$ be the time-dependent density of vehicular movement of size m , moving with velocity v , so that $P_m(v)$ gives the probability that a vehicle picked at random moves with velocity v in a traffic jam of size m .

Also, $U(v, v')$ be the rate at which vehicles with velocity v' are joining the vehicles with velocity v . For the Boltzmann model from the kinetic theory of gases one has

$$U(v, v') = |v - v'| (1 - W(|v - v'|)) \quad (4.3)$$

The term $|v - v'|$ is simply the rate at which clusters with velocity v' and v approach each other, and $(1 - W(|v - v'|))$ is the probability that they will merge, as explained earlier.

Hence, the Master equation governing the time evolution of the joint size-velocity distribution reads

$$\rho \sum_k k \int_0^\infty dv P_k(v, t) = 1 \quad (4.4)$$

2.4 Code Design Approach

Software used to write the codes that drives the hardware is Arduino 1.83 and AVR Studio (Advanced Virtual RISC,) RISC:- (Reduced Instruction Set Computer).

2.4.1 Steps for coding

The proposed algorithm contains five steps:

- Assigning Unique Id to all emergency vehicle
- Determining the queue length (volume) of traffic using adaptive control concept.

- If Emergency Vehicle is present, then determine its scenario (best case or worst case).
- Assigning green light to the most suitable phase for two emergency vehicles on different routes.
- Calculating how much “green light” time must be allotted to the phase decided in (iii). Adaptive control concept will be deployed here.

The flow chart of the entire system is given at Fig.6. It comprises of three sub flow blocks and charts. The first block represents a scenario where there is no emergency vehicle approaching the traffic light. At this point it maintains the normal traffic routine. The second block represents a scenario that emergency vehicle is detected at one of the lanes, it quickly alters the normal routine and give right of way to that particular lane. The last block represents a scenario that another emergency vehicle is detected at another lane while the RFID signal at the second lane is about fading and the emergency vehicle is about passing the traffic lights point.

2.5 Encoding the RFID Tag

An encoder HT12E (Fig. 7) is configured by assigning a unique Id to all the emergency vehicle. It is done by creating a simple database to store vital information about the particular emergency vehicle. The database design is shown on Table 4.

Table 4. Database design for encoding RFID

Field	Data type
Id	Short text
Vehicle Brand	Text
Vehicle Type	Text
Emergency Duty	Text
Vehicle Reg No	Text
City of Operation	Text
Encoded Id	Short text

2.6 Check for Emergency Vehicle Presence

An Emergency vehicle is a vehicle which has to be assigned a greater priority than other motorized vehicles. For this purpose, we first need to assign a priority for different types of emergency vehicles. For example, Fire Trucks can be assigned priority 0 (highest) followed by

ambulance and so on. Assigning priority for the Emergency Vehicles is totally dependent on the standard policies, taking into consideration multiple parameters, and may vary from country

to country. Considering all probable scenarios, we classify the management of Emergency Vehicles on the basis of six cases [8]:

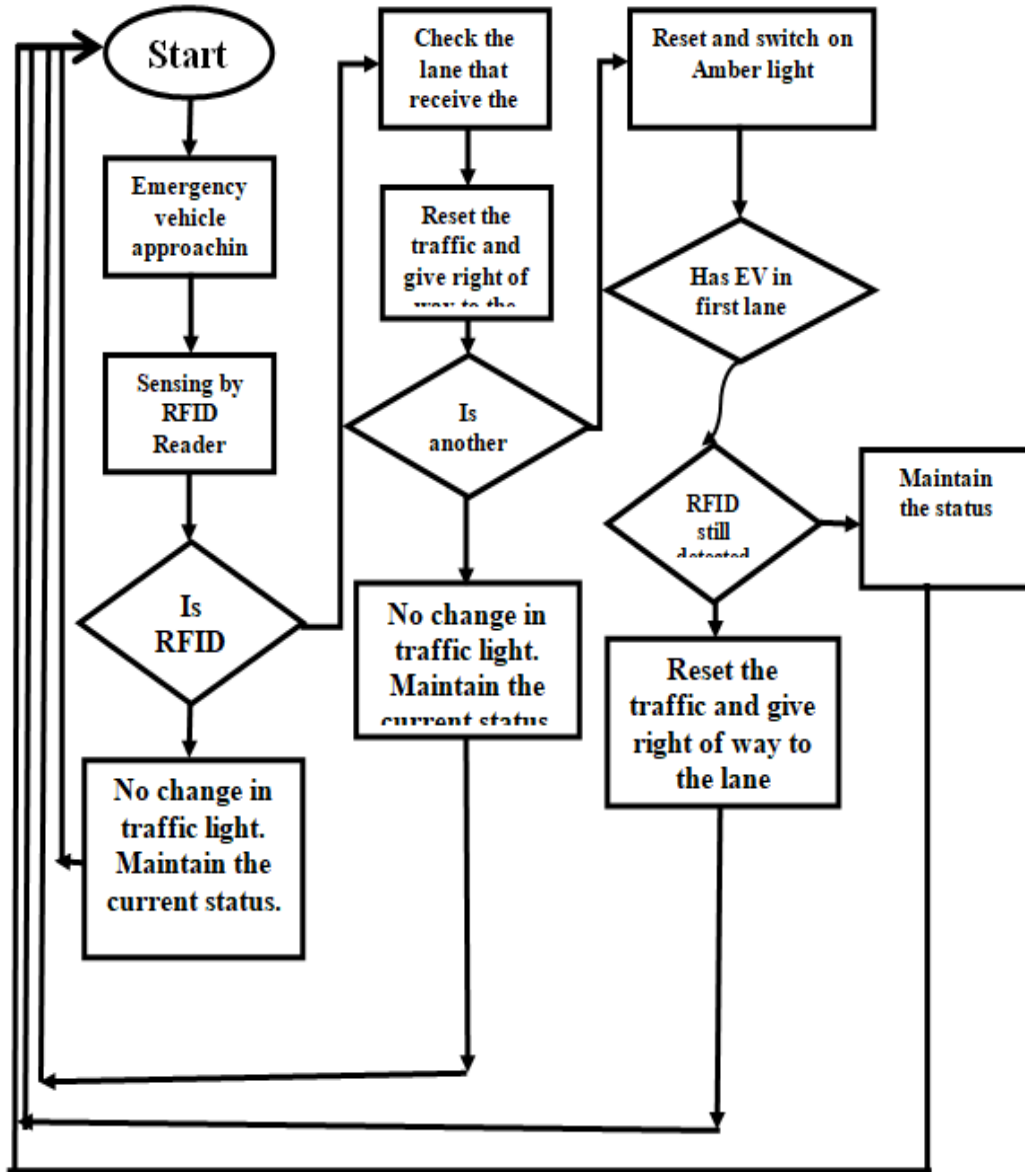

Fig. 6. (a) Flow chart of detailed design and RFID interaction with the Traffic apparatus

Table 5. Sample database of encoded RFID tag for emergency vehicles

id	Vehicle Brand	Vehicle Type	Emergency Duty	Vehicle Reg No	City of Operation	Unique tag ID
1.	Volvo	Saloon	Ambulance	As123LP	Abuja	xxxxxx
2.	Toyota	Truck	Fire Service	DP0911k	Lagos	xxxxxx
3.	Nissan	Saloon	Rescue	Rt145Rt	Port Harcourt	xxxxxx

Case 1: Only One Emergency Vehicle is Present in a Lane. In this case we simply assign green light to the lane where the Emergency Vehicle is present.

Case 2: Two Emergency Vehicles each having different Priority present in two different Lane. In this case we simply allow the vehicle with the higher priority to pass through first, followed by the vehicle with lower priority.

Case 3: Two Emergency Vehicles each having same Priority.

This is a typical scenario since both the Emergency Vehicles have the same priority. In order to tackle such a situation, we need to be fair to both vehicles. Therefore, we assign green light priority first to the Emergency Vehicle present at the shortest distance from the intersection.

Case 4: Four Emergency Vehicles (all different priorities) placed at each of the four lanes [deadlock]

Such a situation can be rightly tackled by assigning Green light to the Emergency Vehicle on the basis of Highest Priority First (HFS) Scheduling.

Case 5: Four Emergency Vehicles (all have same priorities) placed at each of the four lanes [pure deadlock] .

Such a situation can be rightly tackled by assigning Green light to the Emergency Vehicle on the basis of Highest Priority First (HFS) Scheduling with first to the Emergency Vehicle present at the shortest distance from the intersection.

Case 6: Emergency Vehicles are always arriving in particular two phase only [starvation]

Such a situation can be rightly tackled by increase the green light time in repeated interval for other phases, when emergency vehicle is not present in any phase [8].

2.7 Traffic Light Pre-Emption System Design

The pre-emption design is done in such a way that , in case the signal light in the traffic system is struck red and the traffic starts getting jammed, at that time if there is an approach of any emergency vehicle, the RFID receiver will read the signal from the emergency vehicle and reset

the traffic procedure,(Fig. 2). From the flow chart in Fig.2 , if the current light at the traffic system is green, the system is programmed so that there won't be any changes and the normal operation continues. But if the signal light in the traffic system is red and the RFID receiver detects an emergency vehicle approaching that particular lane, the normal operation shuts down and that particular lane is given right of way, thereby turning the traffic light green and the rest are given red till the emergency vehicle crosses the signal path. After which the normal operation of the traffic light system continues.

2.7.1 Assigning green light to most suitable phase

In this step, the queue length (Qx) for each phase is computed according to the dynamic information about traffic volume of various lanes provided by Wireless Sensor Network (WSN).

2.7.2 Determination of green light duration

The third step is to determine as to how much time green light should be assigned to a phase. The maximum normal phase time without emergency vehicle should not be more than 120 seconds. It must be reduced if repeated arrival or high arrival frequency of emergency vehicle in particular phases, to avoid the starvation condition.

2.7.3 Notation used to design proposed algorithm

To design the proposed algorithm, various notations are used. The notations depicting directions, lanes and cases are given as, D: = {North, South, East, West}, L: = {Forward, Right}, C: = {1, 2, 3, 4... 12}.

Here, D, L and C denote the set of directions, lanes and cases respectively. Emergency Vehicle Phase, denoted as EV, of a vehicle is defined as the phase in which a vehicle passes the intersection.

The pseudocode is represented as follows:

Case 01: EV (N, F) = EV
(N, R) = I

Case 02: EV (S, F) = EV
(S, R) = I

Case 03: EV (E, F) = EV
(E, R) = I

Case 04: EV (W, F) = EV
(W, R) = I

Case 05: EV (N, F) = EV
(S, F) = I

Case 06: EV (N, R) = EV
(S, R) = I

Case 07: EV (E, F) = EV
(W, F) = I

Case 08: EV (E, R) = EV
(W, R) = I

Case 09: EV (N, F) = EV
(W, R) = I

Case 10: EV (S, F) = EV
(E, R) = I

Case 11: EV (N, R) = EV
(E, F) = I.

Case 12: EV (S, R) = EV
(W, F) = I

2.8 Detailed Design

Detailed design completes the description of the system at the component level. It includes:

- Configuration item identification,
- Component level specifications,
- Code specifications,
- Hardware specifications,
- Verification procedures,
- Software specifications,
- Intersection installation plans,
- Traffic management centre installation plans, and
- Detailed cost estimates

2.9 Phase Design

The signal design procedure involves six major steps. They include: (1) phase design, (2) determination of amber time and clearance time, (3) determination of cycle length, (4) apportioning of green time, (5) pedestrian crossing requirements, and (6) performance evaluation of the design obtained in the previous steps. The objective of phase design is to separate the conflicting movements in an intersection into various phases, so that

movements in a phase should have no conflicts. If all the movements are to be separated with no conflicts, then a large number of phases are required. In such a situation, the objective is to design phases with minimum conflicts or with less severe conflicts. The first issue is to decide how many phases are required. It is possible to have two, three, four or even more number of phases.

2.10 RFID Integration in the System

The RFID is integrated in both emergency vehicles and the already existing traffic design. The RFID transmitter tag is installed on the emergency vehicle dash board. The RFID receiver is installed on each lane of the route to the traffic system at a distance very close to the traffic system and the sub receiver is integrated in the traffic apparatus. Arduino is used to program ATmega328 Microcontroller to implement the software design that control the system.

2.11 Internal Components of the System

The internal components of the system consist of four modules that are responsible for the general traffic control and the active RFID transmitters and receivers. Fig. 6 is the Transmitter and receiver of the RFID; it will be integrated in Fig. 7. What it does is to receive signals from an active emergency vehicle approaching the traffic light control system. It thereby transmits and notify the traffic controller of the emergence of an emergency vehicle.

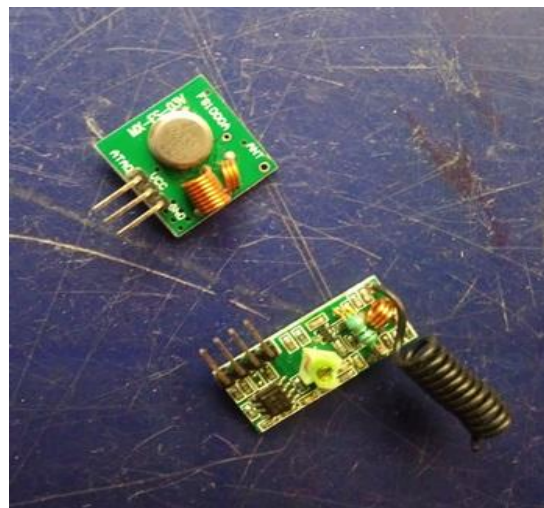

Fig. 7. Transmitter and receiver of the RFID

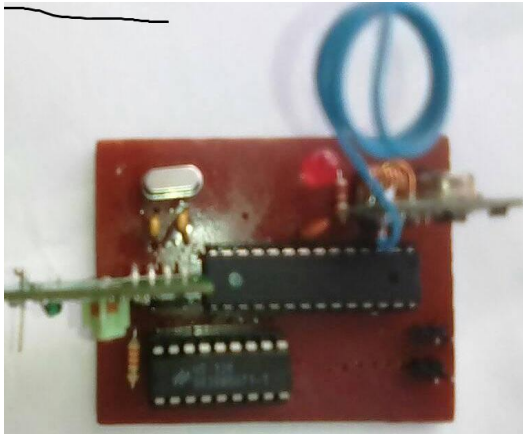

Fig. 8. RFID Receiver and Transmitter installed to be installed on lanes.

Fig 8 is a RFID receiver and transmitter tag. It will be installed on all the lanes leading to the traffic controller. The distance between this tag and the traffic controller apparatus will be 50 meters apart. Its duty is to receive signals from an active emergency vehicle approaching that particular lane, say Lane A when the vehicle is 100 meters away from where Fig 8 is installed. The RFID Receiver and Transmitter tag will now communicate and signal the traffic controller (Fig 10) of the emergency vehicle on its lane. The controller will reset and give right of way to the lane that Fig 8 is installed.

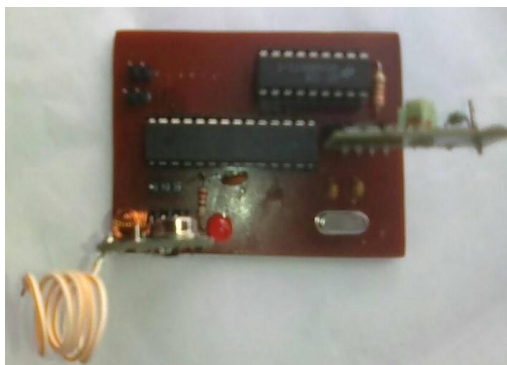

Fig. 9. RFID Receiver and Transmitter signal fading detector.

This tag in Fig 9 will be installed in all lanes. What it does is to notify the traffic control apparatus of the exit of the current active emergency vehicle. This happens immediately the emergency vehicle passes where the receiver is installed. It will afterward prompt the traffic controller to reset to the normal routine.

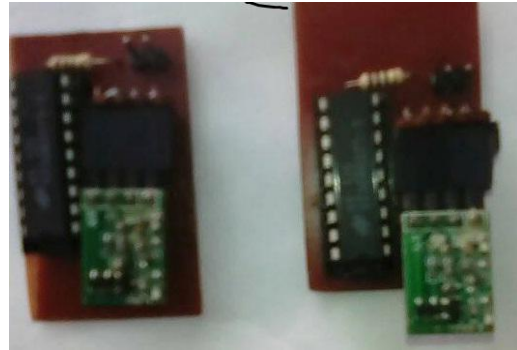

Fig .10. Active RFID Receiver tag

Fig 10 is the tag that will be integrated in Fig 11. Its main duty is to receive signals from Fig 8. The signal is to prompt Fig 11 that an emergency vehicle is in a particular lane. The traffic controller (Fig 11) will thereby give an alarm to notify the road users that an emergency vehicle is approaching. It will thereby reset the traffic proceedings and grant right of way to the particular lane that the signal was received.

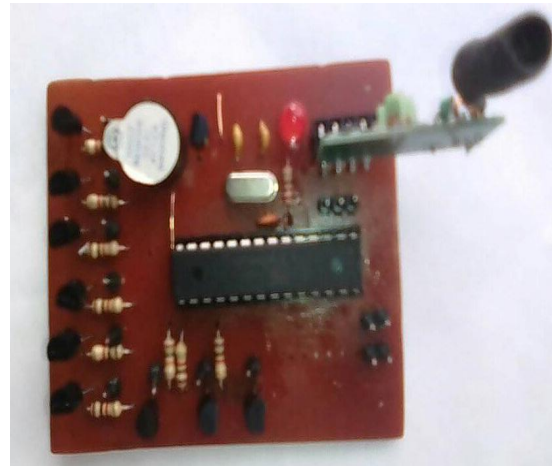

Fig 11. The traffic controller

The main traffic controller is the circuit represented in Fig 11. It handles the automatic traffic routine and the sound prompt to the road users.

2.12 Types of RFID Active, Passive and Bap RFID Systems

2.12.1 Active RFID systems

In active RFID systems, every tag has its own particular transmitter and power source. In most of the cases, the power source is a battery.

Active tags show their own sign to transmit the data put away on their microchips.

Active RFID systems regularly work in the ultra-high recurrence (UHF) band and offer a scope of up to 100 m. By and large, active tags are utilized on expansive items, for example, rail autos, enormous reusable holders, and different resources that should be followed over long separations.



Fig. 12. Active RFID tag

There are two fundamental sorts of active tags: transponders and reference points. Transponders are “woken up” when they get a radio sign from a reader, and after that power on and react by transmitting a sign back. Since transponders don’t effectively emanate radio waves until they get a reader signal, they moderate battery life.

The reference points are not fuelled on by the reader’s sign. Rather, they discharge signals at pre-set interims. Contingent upon the level of finding exactness required, reference points can be set to transmit flags at regular intervals, or once per day. Every reference point’s sign is gotten by reader antennas that are situated around the border of the region being checked, and imparts the tag’s ID data and position.

2.12.2 Passive RFID systems

In passive RFID systems, the reader and reader antenna send a radio sign to the tag. The RFID tag then uses the transmitted sign to control on, and reflect vitality back to the reader. Aloof RFID systems can work in the low recurrence (LF), high recurrence (HF) or ultra-high recurrence (UHF) radio groups. As passive system extents are restricted by the power of the tag’s backscatter (the radio sign reflected from the tag

back to the reader), they are normally under 10 m. Since latent tags don’t require a power source or transmitter, and just require a tag chip and antenna, they are less expensive, littler, and simpler to produce than active tags.

2.12.3 Battery-assisted passive (BAP) systems

A Battery-Assisted Passive RFID tag is a kind of inactive tag that joins a urgent active tag highlight. While most latent RFID tags utilize the vitality from the UHF RFID reader’s sign to control on the tag’s chip and backscatter to the reader, BAP tags utilize a coordinated power source (more often than not a battery) to control on the chip, so the greater part of the caught vitality from the reader can be utilized for backscatter. Not at all like transponders, BAP tags do not consist of their own transmitters.

3. RESULTS SYSTEM IMPLEMENTATION, TESTING AND DISCUSSION

3.1 System Testing

A test conducted was the response of RFID signal at receiver installed in the traffic apparatus when the transmitter transmits the signal at various distances. The test was conducted at the test bed located at Electronics Development Institute (ELDI) at Abba junction, Dunokofia L.G.A, Anambra state. The start-up point from ELDI premises (Test bed location) was Ukpo/Abba T junction (1.5km) from the test bed. The results obtained is as shown on Table 6.

The graph that represents the readings taken in Table 6 is as shown in Fig. 13. plotted in MATLAB. Fig 13 is a graph that was derived from a test conducted to determine the signal strength of RF signal from emergency vehicles at different distances from the test bed at Electronics Development Institute (ELDI) as shown on Table 6. From the graph it is cleared that at a distance of 100 meters and below, the RF signal strength was appreciating. Therefore, the system is designed to detect the presence of an emergency vehicle at a distance of 100 meters away from the traffic light and right of way will be given to that particular lane that the vehicle is detected.

From the graph it is glaring that the signal strength appreciates as the distance is of the emergency vehicle gets closer to the traffic light point.

Table 6. Results of test for RFID receiver response at various distances.

S/N	Distance between RFID transmitter and receiver	Response/Strength of signals	Remarks/ Application
1.	1.5Kilometers	No Response (No Signal)	0% Applicable
2.	1Kilometer	Faint response (Very faint signal)	25% Applicable.
3.	500 Meters apart	Fairly response (Not strong signal)	45% Applicable
4.	200 Meters apart	Good response (strong signal)	80% Applicable
5.	150 Meters apart	Very good response (Stronger signal)	90% Applicable
5.	100 Meters apart	Very good response (Very strong signal)	95%Applicable
6.	50 Meters apart	Excellent response (Excellent signal)	100%Applicable

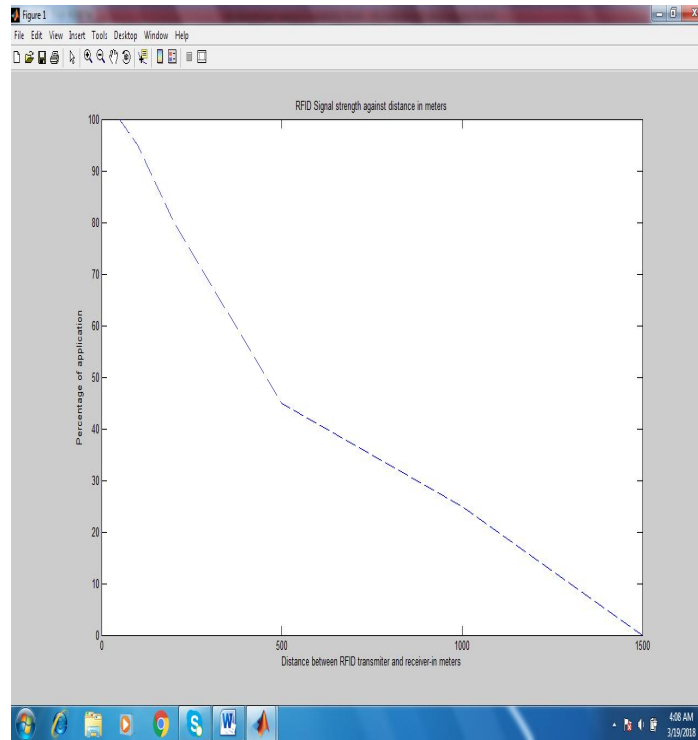

Fig. 13. Matlab graph showing RFID response with distance as obtained from Table 6

3.2 Discussion and Result Analysis

The signals are faint from 150m away from the traffic apparatus; therefore, the traffic light will reset to default after the vehicle with RFID transmitter is 150m away from the traffic system.

Also, in the existing system (existing Traffic light), (existing Traffic Light), the delay experience by Emergency Vehicle (EV) is at least 150 seconds in a very light traffic scenario. The delay may increase to about 2 times or 300 seconds in a heavy traffic scenario. Assuming the EV will pass through 3 different points of heavy traffic before its destination, the time wasted will be $300 \times 3 = 900$ seconds.

The new improved system, the EV will spend on maximum of 60seconds in a very heavy traffic scenario. Assuming the EV will pass up to 3 traffic points of heavy traffic before its destination, the total time that will be wasted will be:

$$60\text{sec} \times 3 = 180 \text{ secs}$$

The old system delay = S_i
 The new system delay = S_n
 The Difference in delay = $S_n - S_i$
 $B = \text{percentage change in delay}$
 $B = ((S_n - S_i) / (S_i)) \times 100$
 $S_i = 300 \times 3 = 900\text{Sec}$
 $S_n = 180 \text{ Sec}$

Table 7. RFIDs Strengths and Weaknesses

	Active RFID	Passive RFID	Battery assisted passive (bap)
Tag Power Source	Internal to Tag	Energy transfer from the reader via RF	Tag uses Internal power source to power on, and energy transferred from the reader via RF to backscatter.
Tag Battery	Yes	No	Yes
Availability of Tag Power	Continuous	Only within field of reader	Only within field of reader.
Required signal strength from Reader to Tag	Very Low	Very high (Must pairs the tag)	Moderate (does not need to power tag, but must power backscatter)
Available signal strength from Tag to Reader	High	Very Low	Moderate
Communication Range	Long Rage (100m or More)	Short Range (Up to 10m)	Moderate range (Up to 100m)
Sensor Capability	Ability to continuous by monitor and record sensor input	Ability to read and transfer sensor values only when tag is powered by reader.	Ability to read and transfer sensor values only when tag receives RF signal from reader.

Table 8. Some Nigeria cities and the percentage of emergency vehicles that ply the roads as given by Federal Road Safety commission

S/N	Nigeria Cities	Private Vehicles	Commercial Vehicles	Emergency Vehicles
1.	Abuja	40%	35%	25%
2.	Awka	45%	45%	10%
3.	Benin City	50%	45%	5%
4.	Calabar	50%	35%	15%
5.	Enugu	50%	35%	15%
6.	Ibadan	45%	48%	7%
7.	Kaduna	42%	50%	8%
8.	Kano	45%	45%	10%
9	Lagos	35%	42	23
10	Port Harcourt	40	40	20

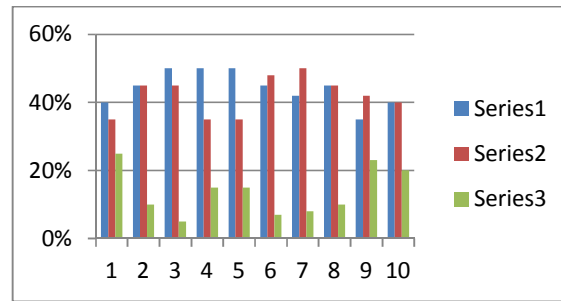

Fig. 14. 3D Column chart: showing percentage of emergency vehicles in selected Nigerian cities

Therefore, the new system will be (900 – 180) faster. = 720 sec or 12minutes faster
 Percentage improvement = ((900 – 180)/180) x 100
 Percentage improvement = 400 %

3.3 Choice of RFID

The Active RFID was the preferred RFID in this project because of its comparative advantages over other available RFIDs. Its performance has many advantages when compared with other RFIDs.

3.4 Significance of the New System

We visited Federal Road Safety Commission (FRSC), Anambra Sector command to ascertain whether this project affirming that It will curb the damages cursed by delays encountered by EV.

We demanded for the states and cities in Nigeria that they Think that the system will be very useful. Table 8 was the List of cities in Nigeria and the percentage of registered EV that Actively ply their routes.

From Table 8 and Fig 14, Nigerian cities like Abuja, Lagos and Port Harcourt have large number of emergency vehicles, the system will be very useful in these cities.

4. CONCLUSION

It is of paramount importance to ensure EV reach their destinations as fast as possible. This work has successfully achieved its goal by integrating RFID tags in both traffic apparatus and emergency vehicles. the system grants right-of-way to all emergency vehicles any time they approach the roads interceptions which the apparatus are installed. This work extensively

utilized prototyping and Software Engineering principles in designing the system in question.

This research work has exposed the simplest method of curbing damages caused by delays encountered by emergency vehicles at roads interceptions that have traffic apparatus installed. Therefore, this work has added, to the body of knowledge, a cost effective and less complex (RFID) technology for curbing delays encountered by emergency vehicles at traffic interceptions.

Further work in this area should endeavour to enhance the reliability and short delay encountered by dual emergency vehicles with the same priority from different routes at the same interception.

COMPETING INTERESTS

Authors have declared that no competing interests exist.

REFERENCES

1. NAEMSP & NASEMSD. Use of Warning Lights and Siren in Emergency Medical Vehicle Response and Patient Transport, Prehospital and Disaster Medicine; 2010.
2. American Society for Testing and Materials.Scope of Performance of EMS Ambulance Operations 2011;F1517-94
3. Manual on Uniform Traffic Devices for Streets and Highways (MUTCD), Edition. United States Department of Transportation, Federal Highway Administration, Washington D.C;2010.
4. Harrison M, Vanny D and George J. Traffic signal light control system using RFID technology. In Proc. IEEE Radio and Wireless symposium. 2013280-283.

5. Urbanik J. Traffic signal state transition logic using enhanced sensor information. 2013;3. International Engineering Symposium - IES. 2015;200-208. Kumamoto University, Japan.
6. Maki, Pamela J. Acoustic and Adverse Weather Traffic Signal Timing. Prepared by Short Elliott Hendrickson, Inc., for the Minnesota Department of Transportation;2014.
7. Adarsh Rajesh, Prachi Shahi. Intelligent Traffic Density Monitoring Using GPS 7th
8. Chakraborty PS, Sinha PR, Tiwari A. Real time optimized traffic management algorithm for intelligent transportation systems. In2015 IEEE International Conference on Computational Intelligence & Communication Technology. 2015;744-749. IEEE.

© 2021 Akpado et al.; This is an Open Access article distributed under the terms of the Creative Commons Attribution License (<http://creativecommons.org/licenses/by/4.0>), which permits unrestricted use, distribution, and reproduction in any medium, provided the original work is properly cited.

Peer-review history:

*The peer review history for this paper can be accessed here:
<https://www.sdiarticle4.com/review-history/69365>*